

污水处理 Sewage Processing

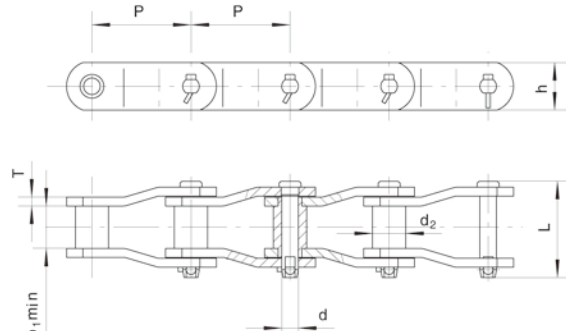

污水处理链 Sewage Treatment Chains



链号 Chain No.	节距 Pitch	内节内宽 Width Between inner sidebars	套筒 外径 Bush diameter	销轴 Pin		链板 Sidebar		最小抗拉强度 Ultimate tensile strength	
	P mm	b ₁ (min) mm	d ₂ (max) mm	d mm	L mm	h mm	T mm	Fu(min) kN	
HB78SS	66.27	28.6	22.23	11.17	66.5	31.8	6	106.6	

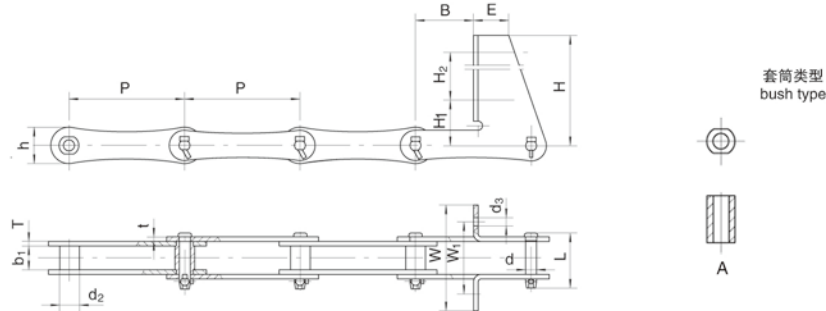

链号 Chain No.	节距 Pitch	内节内宽 Width between inner sidebars	套筒 外径 Bush diameter	销轴 Pin		链板 Sidebar		最小抗拉强度 Ultimate tensile strength Fu(min) kN	
				P mm	b ₁ (min) mm	d ₂ (max) mm	d mm	L mm	h mm
SAV715SS-F228	152.4	30	26	14.5	72.2	48	6	128.9	146.6
FAV715SS-F228	152.4	30	26	14.5	72.2	48	6	128.9	146.6
SS700SS-F226	152.4	30	26	14.5	72.2	48	6	128.9	146.6

链号 Chain No.	W ₁ mm	W mm	B mm	d ₃ mm	E mm	H ₁ mm	H ₂ mm	H mm	套筒类型 Bush Type
SAV715SS-F228	95.3	139.7	76.2	11.1	46	60.3	114.3	200	A
FAV715SS-F228	95.3	139.7	76.2	11.1	46	60.3	114.3	200	B
SS700SS-F226	95.3	139.7	76.2	14.29	46	60.3	66.68	157.2	A

*根据使用要求，可以选用不同的不锈钢材质:304SS 403SS 316SS 17-4PH(630SS)

*According to working requirement, different kinds of stainless steel materials can be selected to use: 304SS 403SS 316SS 17-4PH(630SS)

污水处理链 Sewage Treatment Chains

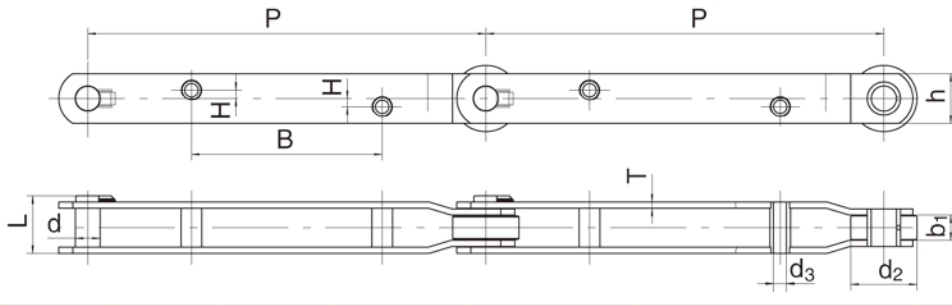

链号 Chain No.	节距 Pitch	内节内宽 Width between inner sidebars	滚子 外径 Roller diameter	支承套 内径 Supporting sleeve diameter	销轴 Pin		链板 Sidebar			最小抗拉 强度 Ultimate tensile strength	每米 重量 Weight per meter	
	P mm	b ₁ (min) mm	d ₂ (max) mm	d ₃ mm	d mm	L mm	h mm	T mm	B mm	H mm	Fu(min) kN	q kg/m
ZY15050	609.6	38	101.6	20.5	30.56	88.1	76.2	9.5	292.1	12.7	370	17.4
ZY15055	609.6	38	101.6	20.5	30.56	88.1	76.2	9.5	292.1	12.7	370	17.4
ZY15060	609.6	38	101.6	20.5	30.56	88.1	76.2	9.5	292.1	12.7	370	17.4
ZY15065	609.6	38	101.6	20.5	30.56	100.8	76.2	12.7	292.1	12.7	490	21.6
ZY15090	609.6	38	101.6	20.5	38.15	88.1	76.2	9.5	292.1	12.7	370	17.5
7497X39	609.6	39.3	101.6	20.24	30.73	84.14	76.2	9.5	292.1	12.7	370	17.37

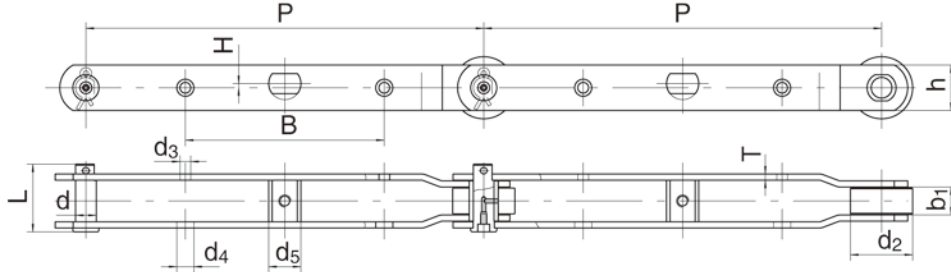

链号 Chain No.	节距 Pitch	内节内宽 Width between inner sidebars	滚子 外径 Roller diameter	支承套 外径 Supporting sleeve diameter	销轴 Pin		链板 Sidebar					最小抗拉 强度 Ultimate tensile strength	每米 重量 Weight per meter
	P mm	b ₁ (min) mm	d ₂ (max) mm	d ₃ mm	d mm	L mm	h mm	T mm	B mm	d ₃ mm	d ₄ mm	Fu(min) kN	q kg/m
ZY15070	609.6	42.9	95.25	49.2	31.8	100.3	69.85	9.5	304.8	16.7	26.2	289	16.8
ZY15075	609.6	41.2	95.25	49.2	31.8	110.9	69.85	12.7	304.8	16.7	26.2	289	20.8
ZY15080	609.6	42.9	95.25	49.2	31.8	100.3	69.85	9.5	304.8	16.7	26.2	289	17.2

*根据使用要求，可以选用不同的不锈钢材质:304SS 403SS 316SS 17-4PH(630SS)

*According to working requirement, different kinds of stainless steel materials can be selected to use: 304SS 403SS 316SS 17-4PH(630SS)