

挖沟机 Trencher

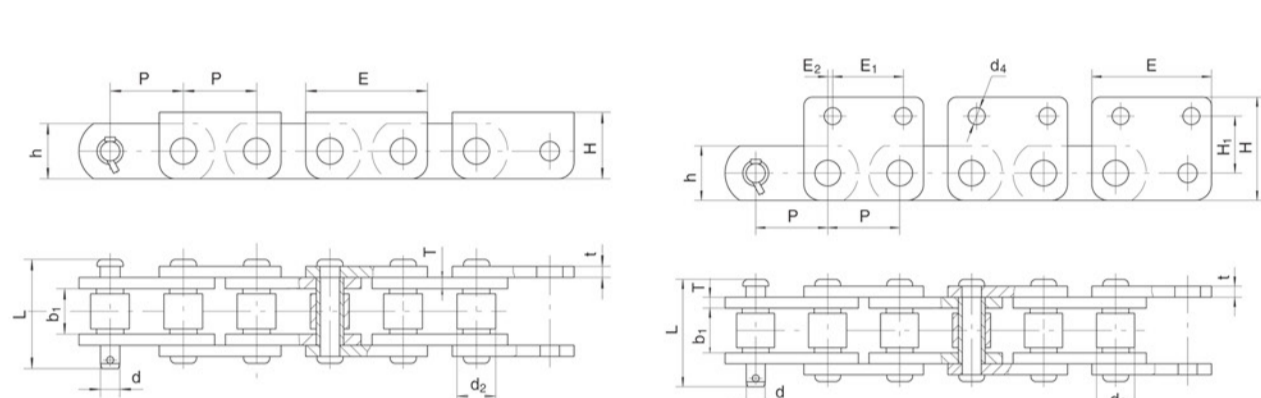

挖沟机链 Trencher Chains



链号 Chain No.	节距 Pitch	内节内宽 Width between inner sidebars	滚子直径 Roller diameter	销轴 Pin		链板 Sidebar		最小抗拉强度 Ultimate tensile strength	每米重量 Weight per meter	附件 ATT.					
	P mm	b.(min) mm	d.(max) mm	d mm	L mm	t/T mm	h mm	Fu(min) kN	q kg/m	H1 mm	H mm	E mm	E1 mm	E2 mm	d4 mm
2250GL-M	42.01	25.2	22.23	11.1	56.3	4.9	31.8	120	6.57	-	38.1	69.8	-	-	-
2250GL-M2	42.01	25.2	22.23	11.1	63.8	6.4	31.8	120	9.47	33.3	60.3	69.8	41.3	2.9	9.95
408LP	103.78	40.5	44.45	22.23	115.2	12.7	76.2	450	31.9	-	82.6	182.4	-	-	-

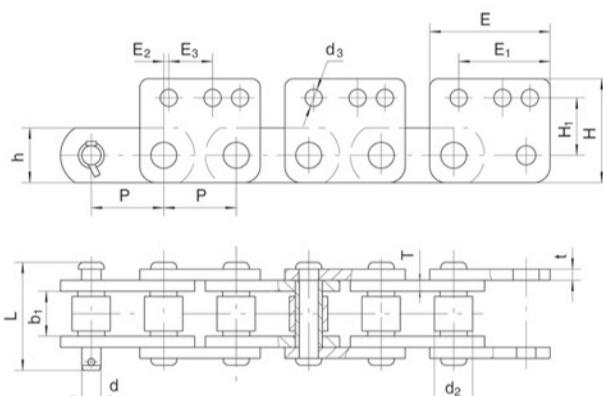

链号 Chain No.	节距 Pitch	内节内宽 Width between inner sidebars	滚子直径 Roller diameter	销轴 Pin		链板 Sidebar		最小抗拉强度 Ultimate tensile strength	每米重量 Weight per meter	附件 ATT.						
	P mm	b.(min) mm	d.(max) mm	d mm	L mm	t/T mm	h mm	Fu(min) kN	q kg/m	H1 mm	H mm	E mm	E1 mm	E2 mm	E3 mm	d4 mm
2250GL-M3	42.01	25.2	22.23	11.1	26.9	29.4	31.8	4.9	120	33.3	60.3	69.8	41.3	2.9	25.4	9.95

挖沟机链 Trencher Chains

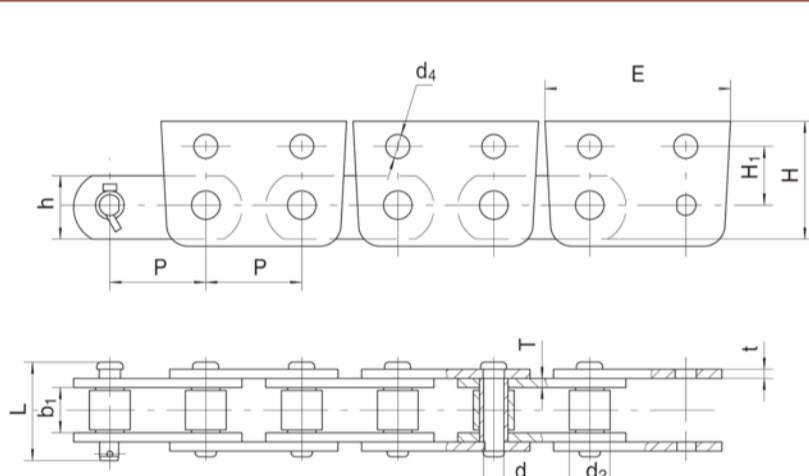

链号 Chain No.	节距 Pitch	滚子外径 Roller diameter	内节内宽 Width between inner sidebars	销轴 Pin		链板 Sidebar		最小抗拉强度 Ultimate tensile strength	每米重量 Weight per meter	附件 ATT.			
	P mm	d.(max) mm	b.(min) mm	d mm	L mm	h mm	t/T mm	Fu(min) kN	q kg/m	H1 mm	H mm	E mm	d4 mm
50.8K	50.8	31.1	28.58	14.17	73.1	38.1	6.4	189	13.8	38.1	76.2	100	13.5

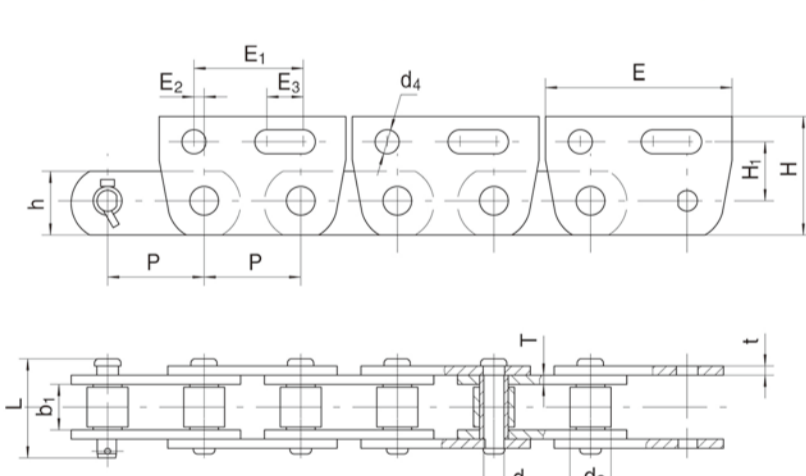

链号 Chain No.	节距 Pitch	滚子外径 Roller diameter	内节内宽 Width between inner sidebars	销轴 Pin		链板 Sidebar		最小抗拉强度 Ultimate tensile strength	每米重量 Weight per meter	附件 ATT.						
	P mm	d.(max) mm	b.(min) mm	d mm	L mm	h mm	t/T mm	Fu(min) kN	q kg/m	H1 mm	H mm	E mm	E1 mm	E2 mm	E3 mm	d4 mm
2600	67.31	31.1	28.58	14.27	73.1	44.5	6.4	189	13.1	41.28	82.6	132	76.2	7.1	25.4	16.8

挖沟机链 Trencher Chains

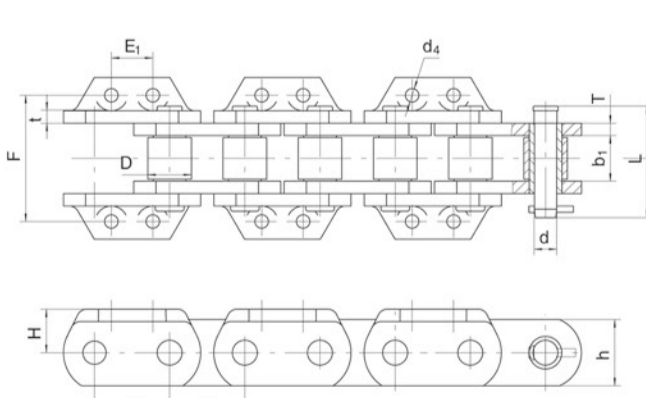

链号 Chain No.	节距 Pitch	滚子直径 Roller diameter	内节内宽 Width between inner sidebars	销轴 Pin		链板 Sidebar					最小抗拉强度 Ultimate tensile strength	每米重量 Weight per meter	
	P mm	d2(max) mm	b1(min) mm	d mm	L mm	h mm	t/T mm	H mm	E1 mm	F mm	d3 mm	Fu(min) kN	q kg/m
2109	101.6	50.8	40.7	25.4	120.2	76.2	12.7	50.8	63.5	152.4	20.6	622	44.2
4501	114.3	63.5	56.8	34.93	158	101.6	10.6	49.2	63.5	177.8	19.8	1100	56.6
4501XHD	114.3	63.5	56.8	34.93	158	88.9	19.05	58.7	63.5	177.8	19.8	1150	73.8
4550	114.3	63.5	68.7	33.2	164	88.9	15.9	57.2	63.5	190.5	19.8	1100	64.98
4525	114.93	66.67	56.8	38.1	145.1	95.2	15.9	61	63.5	177.8	20.2	1350	66.6
4525XHD	114.93	66.67	56.8	41.28	157.7	98.5	15.9/19.05	61	63.5	177.8	19.8	1420	77.1
4555	114.93	66.67	69.5	38.1	163.7	95.2	15.9	61	63.5	192	20.6	1350	69.2
P115.09	115.09	66.67	69.8	35	174.1	101.6	19.05	66.7	63.5	192.1	20.5	1150	80.0
P167.38	167.38	98.43	87	54	201.7	139.7	19.05/22.23	82.6	63.5	231.8	26.2	2730	122.0

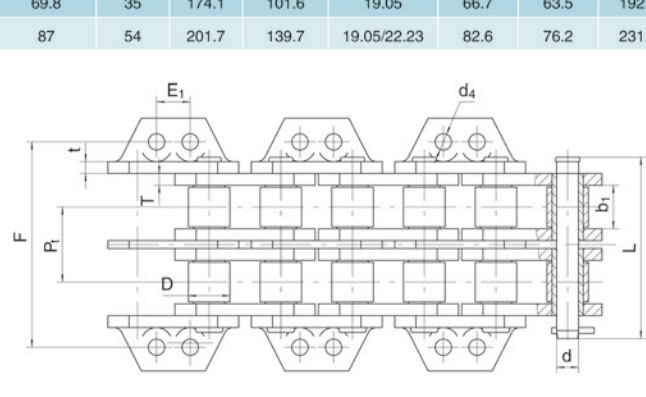

链号 Chain No.	节距 Pitch	滚子直径 Roller diameter	内节内宽 Width between inner sidebars	销轴 Pin		链板 Sidebar					最小抗拉强度 Ultimate tensile strength	每米重量 Weight per meter		
	P mm	d2(max) mm	b1(min) mm	d mm	L mm	h mm	t/T mm	H mm	E1 mm	F mm	d3 mm	Fu(min) kN	q kg/m	
4502	114.3	63.5	56.8	107.95	33.2	259.8	88.9	15.9	49.2	63.5	284.2	19.8	2100	94.0
5503	115.09	66.67	69.8	122.24	35	299.3	101.6	19.05	66.7	54	330.2	26	2300	135.8