

空心销轴型棕榈油链 Hollow Pin Type Palm Oil Chains

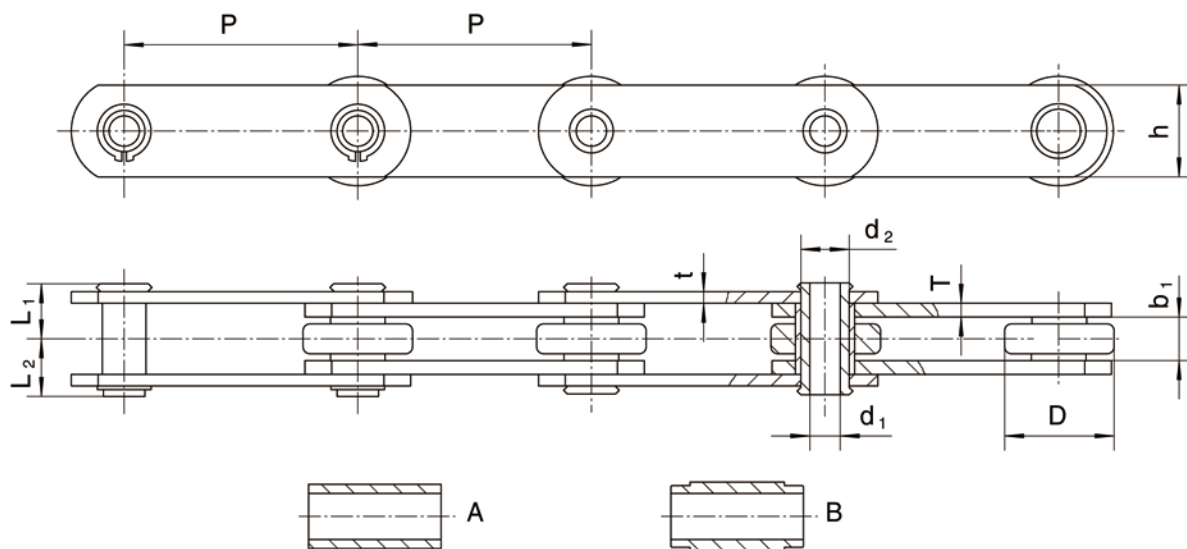

链号	节距	内节内宽	滚子外径	销轴					链板		最小抗拉强度	每米重量			
Chain No	Pitch	Width Between Inner Plates	Roller Diameter	Pin					Plate		Ultimate Tensile Strength	Weight Per Meter			
				D(max)	d1	d2	L1	L2	Type	h			t/T	Fu(min)	q
4 × 15000HP	101.6	18.9	47.63	13.1	19.05	24.2	24.8	A	40	5/6	66.7	6.92			
4 × 21000HP	101.6	19.05	47.63	13.1	19.05	23	24	B	39.4	5.1	95	6.56			
RF4 × 21000HP	101.6	19.05	47.63	13.2	19.05	23.05	29.45	B	39.4	5.1	95	6.52			
4 × 30000HP	101.6	25.4	66.7	19.56	25.8	28.8	29.4	B	50.8	5.1/7.1	200	12.723			
6 × 35000HP	152.4	25.4	66.7	20.1	25.8	27.7	28.3	B	50.8	5.1/6	177.8	9.52			
6 × 36000HP	152.4	25.4	66.7	20.1	26.9	28.8	29.4	B	50.8	5.1/7.1	200	10.1			
IK6 × 36000HP	152.4	25.4	66.7	20.1	26.9	29.3	31.6	B	60.8	7.1/7.1	200	11			
RF6 × 36000HP	152.4	25.4	66.7	20.1	26.9	29.4	30	A	50.8	6.4/6.4	200	10.35			
6 × 36000HHP	152.4	25.4	66.7	20.1	26.9	30.8	31.6	B	50.8	6.4/7.8	220	11.06			
6 × 50000HP	152.4	25.4	66.7	20.24	26.9	31	31.8	B	50.8	6.4/8	220	11.1			
6 × 65000HP	152.4	25.4	66.7	20.24	28	32.6	33.4	B	50.8	8	288.9	11.763			
8 × 45000HP	203.2	38.1	88.9	22.85	30	40	44.2	A	61	8	280	17.27			